

FILTRY

PROSTE, KĄTOWE I TYPU "Y"



ZAKRES INFORMACJI	STRONA
OGÓLNE DANE PRODUKTU	2-4
OZNACZENIA W KATALOGU	5
OPIS NORM	6
WARIANTY I DANE TECHNICZNE	7-10

FILTR PROSTY

CECHY PRODUKTU

- Estetyczna i łatwa w konserwacji konstrukcja
- Wykonane ze stali nierdzewnej AISI 304L lub 316L
- Dostępne według DIN, SMS i Clamp
- Polerowane wykończenie powierzchni zewnętrznej

*strona www
produktu*

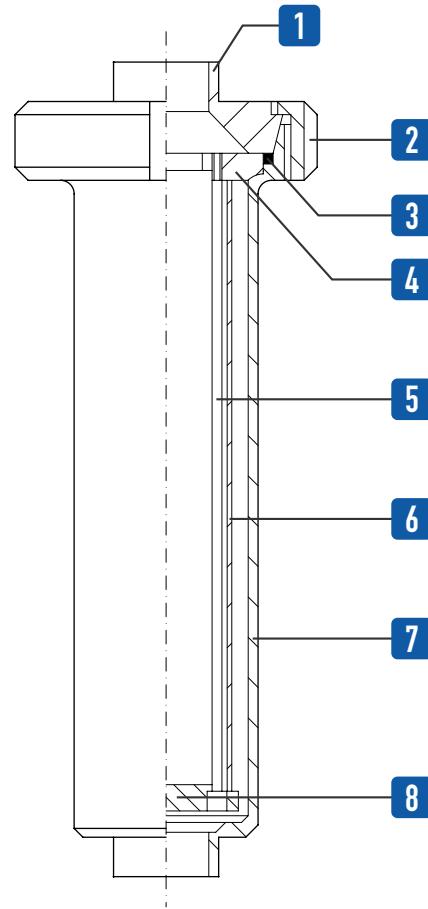

MATERIAŁ	USZCZELNIENIE	MAX [°C]
AISI 304L	NBR	+100
AISI 316L	NBR	+100

SYMBOL	CZĘŚĆ	MATERIAŁ	ILOŚĆ
1	Przyłącze	304/316	1
2	Nakrętka	304/316	1
3	Uszczelnienie	NBR	1
4	Dysk górny	316	1
5	Pręt kierowniczy	316	1
6	Siatka filtrująca	316	1
7	Obudowa	304/316	1
8	Dysk dolny	316	1

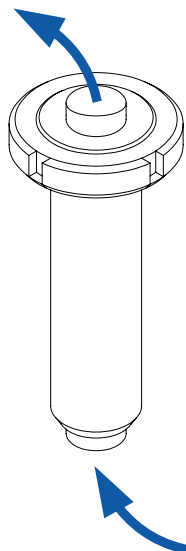

FILTR KĄTOWY

CECHY PRODUKTU

- Estetyczna i łatwa w konserwacji konstrukcja
- Wykonane ze stali nierdzewnej AISI 304L lub 316L
- Dostępne według DIN, SMS i Clamp
- Polerowane wykończenie powierzchni zewnętrznej

strona www produktu

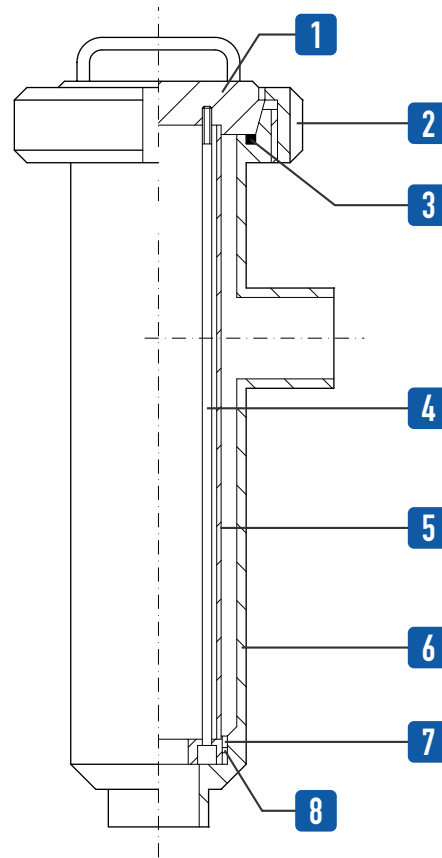

MATERIAŁ	USZCZELNIENIE	MAX [°C]
AISI 304L	NBR	+100
AISI 316L	NBR	+100

SYMBOL	CZĘŚĆ	MATERIAŁ	ILOŚĆ
1	Domknięcie z uchwytem	304/316	1
2	Nakrętka	304/316	1
3	Uszczelnienie	NBR	1
4	Pręt kierowniczy	316	1
5	Siatka filtrująca	316	1
6	Obudowa	304/316	1
7	Dysk dolny	316	1
8	O-ring	NBR	1

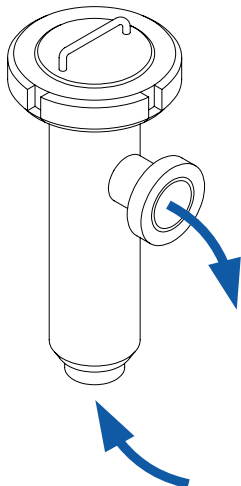

FILTR TYPU "Y"

CECHY PRODUKTU

- Estetyczna i łatwa w konserwacji konstrukcja
- Wykonane ze stali nierdzewnej 316L
- Dostępne według DIN i Clamp
- Szlifowane wykończenie powierzchni zewnętrznej

*strona www
produktu*

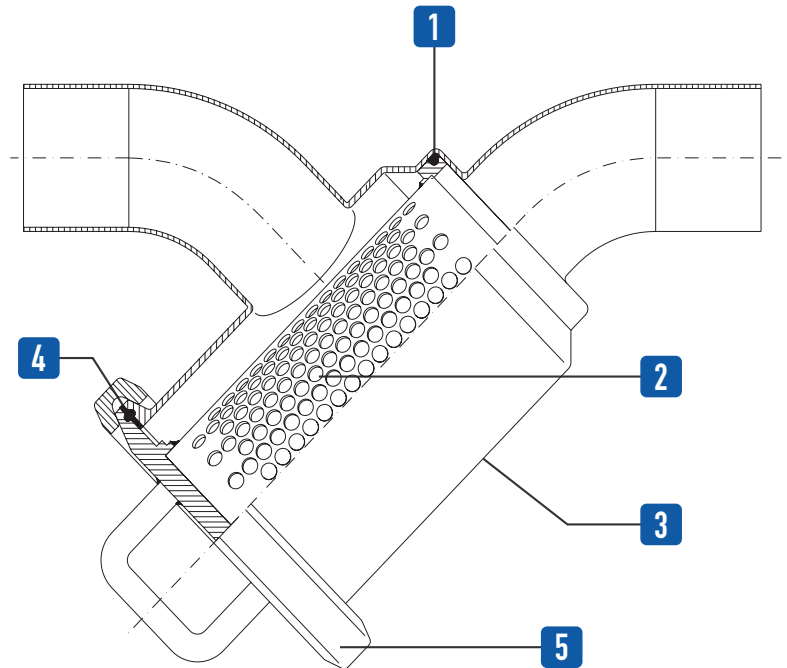

MATERIAŁ	USZCZELNIENIE	MAX [°C]
AISI 316L	EPDM	+140

SYMBOL	CZĘŚĆ	MATERIAŁ	ILOŚĆ
1	O-ring	EPDM	1
2	Siatka filtrująca	316	1
3	Obudowa	316	1
4	Uszczelnienie zacisku	EPDM	1
5	Zacisk clamp	316	1

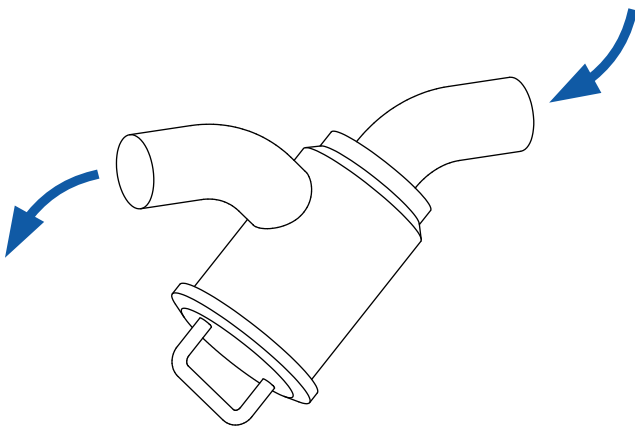

ZAWORY KULOWE 2-DROGOWE (PRZELOTOWE)

2100/DD ZAWÓR KULOWY DIN GWINT / GWINT (ME. / ME.)

2100/ED ZAWÓR KULOWY DIN NAKŁĘTKA / GWINT (FE. / ME.)

2100/FD ZAWÓR KULOWY DIN SPRAW / GWINT (PE. / ME.)

2100/FF ZAWÓR KULOWY DIN SPRAW / SPRAW (PE. / PE.)

2100/AA ZAWÓR KULOWY BSP-GAS GWINT ME. / GWINT (FE. / FE.)

2100/BA ZAWÓR KULOWY BSP-GAS GWINT ZE. / GWINT (ME. / ME.)

N°	DN	F	A	B	C	D	E	H	Hd
1	10	28	10	28	70	75	58	0.30	
2	15	34	15	35	72	82	67	0.40	
3	20	44	20	40	65	82	70	0.50	
4	25	52	25	50	96	98	75	1.10	
5	32	58	32	58	98	120	101	1.60	
6	40	65	36	62	104	120	101	1.70	
7	50	78	45	78	115	153	120	2.80	
8	50	78	50	90	133	153	125	3.80	
9	60	85	57	100	138	153	130	4.40	
10	65	95	66	114	165	190	158	7.00	
11	80	110	76	133	184	248	193	10.20	
12	100	130	98.5	160	198	248	230	15.00	

2100/DD ZAWÓR KULOWY DIN GWINT / GWINT (ME. / ME.)

N°	DN	H (mm)	A (mm)	B (mm)	C (mm)	D (mm)	E (mm)	(kg)
1	10	28	10	28	70	75	58	0.30
2	15	34	15	35	72	82	67	0.40
3	20	44	20	40	65	82	70	0.55
4	25	52	25	50	96	98	75	1.10
5	32	58	32	58	98	120	101	1.60
6	40	65	36	62	104	120	101	1.70
7	50	78	45	78	115	153	120	2.80
8	50	78	50	90	133	153	125	3.80
9	60	85	57	100	138	153	130	4.40
10	65	95	66	114	165	190	158	7.00
11	80	110	76	133	184	248	193	10.20
12	100	130	98.5	160	198	248	230	14.80

SYMBOL	OZNACZENIE
A	Nazwa kategorii
B	Nazwa podkategorii
C	Numer katalogowy oraz norma przyłącza (oznaczona kolorem)
D	Numer wykonawczy
E	Rysunek elementu
F	Tabela wymiarów
G	Nazwa produktu
H	Oznaczenia przyłączy

SYMBOL	ROZWIŃCIE	PRZYŁĄCZE
PE.	PLAIN END	do przyspawania
ME.	MALE END	męskie
FE.	FEMALE END	żeńskie
CL.	CLAMP	
GR.	GAROLLA	

SYMBOL	NORMA
	DIN
	BSP-GAS
	SMS
	CLAMP
	GAROLLA / MACON / ENO
	NIE DOTYCZY

*Dane w katalogu mogą nieznacznie odbiegać od wartości rzeczywistych - zastrzegamy sobie prawo do zmiany konfiguracji bez wcześniejszego powiadomienia.

DIN DIN 11851

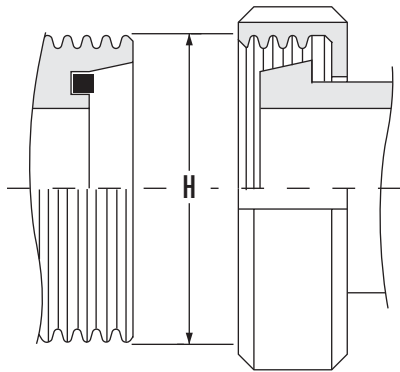

CZĘŚĆ MĘSKA
GWINT (ME.)

CZĘŚĆ ŻEŃSKA
STOŻEK + NAKRĘTKA (FE.)

DN	[mm x cal]
10	28 x 1/8
15	34 x 1/8
20	44 x 1/6
25	52 x 1/6
32	58 x 1/6
40	65 x 1/6
50	78 x 1/6
60	85 x 1/6
65	95 x 1/6
80	110 x 1/4
100	130 x 1/4
125	160 x 1/4
150	190 x 1/4

SMS SMS 1146

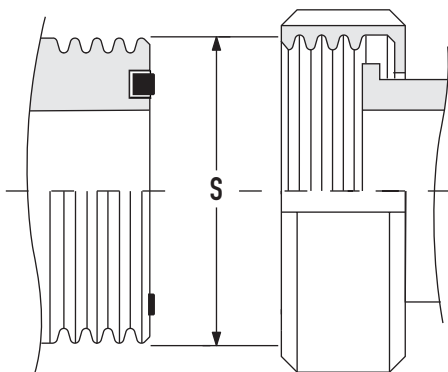

CZĘŚĆ MĘSKA
GWINT (ME.)

CZĘŚĆ ŻEŃSKA
STOŻEK + NAKRĘTKA (FE.)

DN	[cal]	S [mm x cal]
25	1	40 x 1/6
38	1 1/2	60 x 1/6
51	2	70 x 1/6
63	2 1/2	85 x 1/6
76	3	98 x 1/6
101	4	132 x 1/6
104	-	125 x 1/4

CLAMP BS 4825 / ISO 2852 / DIN 32676

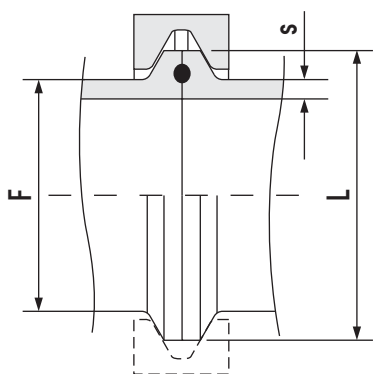

CLAMP
CLAMP (CL.)

OBEJMA

CLAMP
CLAMP (CL.)

	DN [cal]	L [mm]	F [mm]	S [mm]
BS 4825	1/2	25.1	12.7	1.65
	3/4	25.1	19.05	1.65
	1	50.4	25.4	1.65
	1 1/2	50.4	38.1	1.65
	2	64.0	50.8	1.65
	1 1/2	77.4	63.5	1.65
	3	90.9	76.1	1.65
	4	118.8	101.6	2.11
	6	167.0	152.4	2.77
	8	217.4	203.2	2.77
	10	268.5	254.0	3.56
	12	319.3	304.8	3.56

3270/99

SIATKA FILTRA MESH
DLA SERII 3250 i 3260

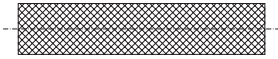

3280/99

**CARTRIDGE
FILTRA PROSTEGO**
DLA SERII 3260

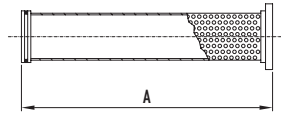

3290/99

**CARTRIDGE
FILTRA KĄTOWEGO 90°**
DLA SERII 3250

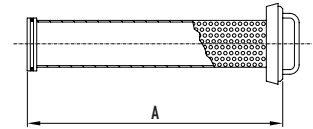

N°	DN	MESH			
1	25 / 40	100 / 200	300	400	500
2	50 / 51	100 / 200	300	400	500
3	63 / 70	100 / 200	300	400	500
4	76 / 80	100 / 200	300	400	500
5	100 / 101	100 / 200	300	400	500

N°	DN	A [mm]
1	25 / 40	271
2	50 / 51	371
3	63 / 70	466
4	76 / 80	516
5	100 / 101	621

N°	DN	A [mm]
1	25 / 40	278
2	50 / 51	378
3	63 / 70	473
4	76 / 80	527
5	100 / 101	636

3260/FF

FILTR PROSTY DIN
SPAW / SPAW (PE. / PE.)

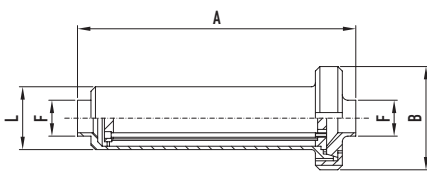

3260/ED

FILTR PROSTY DIN
NAKRĘTKA / GWINT (FE. / ME.)

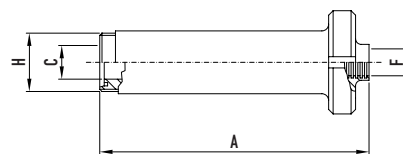

3260/JJ

FILTR PROSTY SMS
SPAW / SPAW (PE. / PE.)

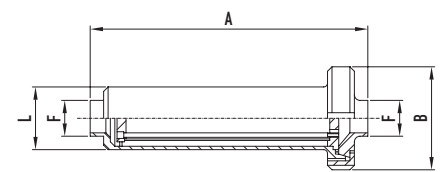

N°	DN	F [mm]	L [mm]	A [mm]	B [mm]	[kg]
1	25	28	70	320	112	3.00
2	32	34	70	320	112	3.00
3	40	40	70	320	112	3.00
4	50	52	70	420	112	3.30
5	65	70	85	516	127	4.65
6	80	85	102	575	148	5.70
7	100	101.6	129	700	148	7.00
8	101	104	129	700	148	7.00

N°	DN	H [mm x cal]	F [mm]	A [mm]	C [mm]	[kg]
1	25	52 x 1/6	28	320	25	3.13
2	32	58 x 1/6	34	320	31	3.17
3	40	65 x 1/6	40	320	37	3.21
4	50	78 x 1/6	52	420	49	3.58
5	65	95 x 1/6	70	521	66	5.03
6	80	110 x 1/4	85	584	81	6.30
7	100	130 x 1/4	101.6	690	97.6	8.00
8	101	130 x 1/4	104	690	100	8.00

N°	DN	F [mm]	L [mm]	A [mm]	B [mm]	[kg]
1	25	25.4	70	320	112	3.00
2	38	38.1	70	320	112	3.00
3	51	50.8	70	420	112	3.30
4	63	63.5	85	516	127	4.65
5	76	76.2	102	574	148	5.70
6	101	101.6	129	700	148	7.00

3260/IH

FILTR PROSTY SMS
NAKRĘTKA / GWINT (FE. / ME.)

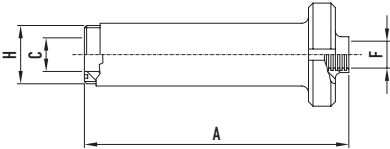

N°	DN	H (mm x cal)	F (mm)	A (mm)	C (mm)	(kg)
1	25	40 x 1/6	25.4	327	22.4	3.07
2	38	60 x 1/6	38.1	327	35.1	3.20
3	51	70 x 1/6	50.8	427	47.8	3.53
4	63	85 x 1/6	63.5	529	60.5	5.04
5	76	98 x 1/6	76.2	594	72.9	6.20
6	101	132 x 1/6	101.6	700	97.6	8.14

3260/MM

FILTR PROSTY CLAMP
SPAŃ / SPAW (PE. / PE.)

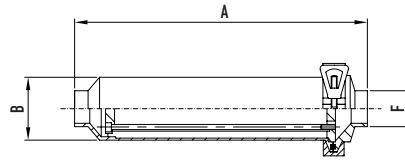

N°	DN (cal)	F (mm)	B (mm)	A (mm)	(kg)
1	1	25.4	70	326	3.00
2	1 1/2	38.1	70	326	3.00
3	2	50.8	70	426	3.30
4	2 1/2	63.5	85	524.5	4.65
5	3	76.2	101	568	5.70

3260/LL

FILTR PROSTY CLAMP
CLAMP / CLAMP (CL. / CL.)

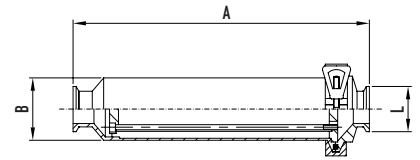

N°	DN (cal)	L (mm)	B (mm)	A (mm)	(kg)
1	1	50.4	70	326	3.17
2	1 1/2	50.4	70	326	3.30
3	2	64	70	426	3.62
4	2 1/2	77.4	85	524.5	5.19
5	3	90.9	101	568	6.40

3250/FF

FILTR KĄTOWY 90° DIN
SPAŃ / SPAW (PE. / PE.)

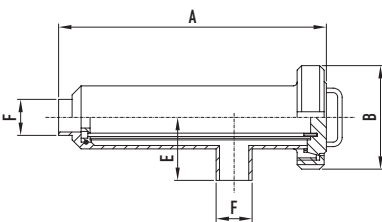

N°	DN	F (mm)	E (mm)	A (mm)	B (mm)	(kg)
1	25	28	70	306	112	3.10
2	32	34	70	306	112	3.10
3	40	40	70	306	112	3.10
4	50	52	72	406	112	3.40
5	65	70	85	503	127	4.80
6	80	85	96	561	148	5.90
7	100	101.6	117	662	148	7.20
8	101	104	117	662	148	7.20

3250/FD

FILTR KĄTOWY 90° DIN
SPAŃ / GWINT (PE. / ME.)

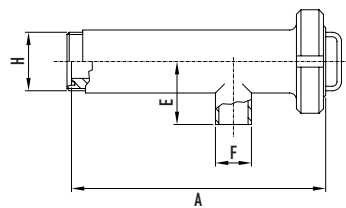

N°	DN	H (mm x cal)	F (mm)	E (mm)	A (mm)	(kg)
1	25	52 x 1/6	28	70	300	3.23
2	32	58 x 1/6	34	70	300	3.27
3	40	65 x 1/6	40	70	300	3.31
4	50	78 x 1/6	52	72	398	3.68
5	65	95 x 1/6	70	85	495	5.18
6	80	110 x 1/4	85	96	553	6.70
7	100	130 x 1/4	101.6	117	642	8.20
8	101	130 x 1/4	104	117	642	8.20

3250/DD

FILTR KĄTOWY 90° DIN
GWINT / GWINT (ME. / ME.)

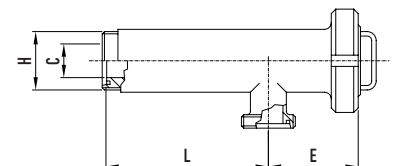

N°	DN	H (mm x cal)	L (mm)	E (mm)	C (mm)	(kg)
1	25	52 x 1/6	200	100	25	3.36
2	32	58 x 1/6	200	100	31	3.44
3	40	65 x 1/6	200	100	37	3.52
4	50	78 x 1/6	283	115	49	3.96
5	65	95 x 1/6	378	117	66	5.56
6	80	110 x 1/4	422	131	81	7.10
7	100	130 x 1/4	522	120	97.6	9.20
8	101	130 x 1/4	522	120	100	9.20

3250/JJ

FILTR KĄTOWY 90° SMS
SPAŹ / SPAW (PE. / PE.)

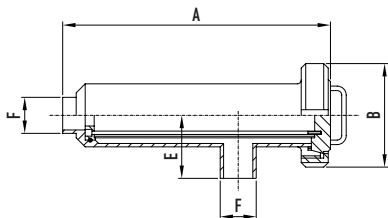

N°	DN	F (mm)	A (mm)	E (mm)	B (mm)	(kg)
1	25	25.4	307	70	112	3.10
2	38	38.1	307	70	112	3.10
3	51	50.8	407	82	112	3.40
4	63	63.5	503	85	127	4.80
5	76	76.2	561	96	148	5.90
6	101	101.6	662	117	148	7.20

3250/JH

FILTR KĄTOWY 90° SMS
SPAŹ / GWINT (PE. / ME.)

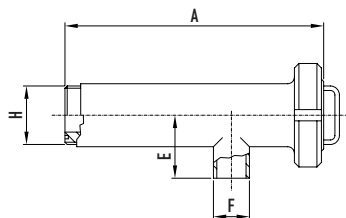

N°	DN	H (mm x cal)	F (mm)	A (mm)	E (mm)	(kg)
1	25	40 x 1/6	25.4	306	70	3.17
2	38	60 x 1/6	38.1	306	70	3.30
3	51	70 x 1/6	50.8	405	72	3.62
4	63	85 x 1/6	63.5	503	85	5.19
5	76	98 x 1/6	76.2	561	96	6.40
6	101	132 x 1/6	101.6	652	117	8.34

3250/HH

FILTR KĄTOWY 90° SMS
GWINT / GWINT (ME. / ME.)

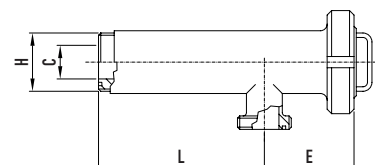

N°	DN	H (mm x cal)	L (mm)	E (mm)	C (mm)	(kg)
1	25	40 x 1/6	207	99	22.4	3.24
2	38	60 x 1/6	207	99	35.1	3.50
3	51	70 x 1/6	290	115	47.8	3.85
4	63	85 x 1/6	386	117	60.5	5.58
5	76	98 x 1/6	430	131	72.9	6.90
6	101	132 x 1/6	532	120	97.6	9.48

3250/MM

FILTR KĄTOWY 90° CLAMP
SPAŹ / SPAW (PE. / PE.)

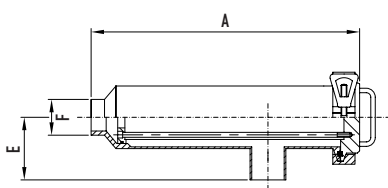

N°	DN (cal)	F (mm)	E (mm)	A (mm)	(kg)
1	1	25.4	70	304	3.10
2	1 1/2	38.1	70	304	3.10
3	2	50.8	72	404	3.40
4	2 1/2	63.5	85	497	4.80
5	3	76.2	96	548	5.90

3250/MM

FILTR KĄTOWY 90° CLAMP
CLAMP / CLAMP (CL. / CL.)

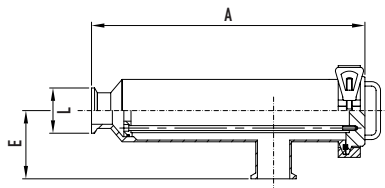

N°	DN (cal)	L (mm)	E (mm)	A (mm)	(kg)
1	1	50.4	82.7	304	3.24
2	1 1/2	50.4	82.7	304	3.50
3	2	64	84.7	404	3.85
4	2 1/2	77.4	97.7	497	5.59
5	3	90.9	108.7	548	6.90

3240/FF

FILTR TYPU "Y" DIN
SPAŹ / SPAW (PE. / PE.)

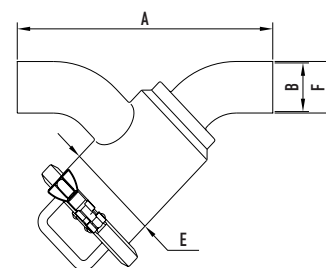

N°	DN	F (mm)	B (mm)	A (mm)	E (mm)	(kg)
1	25	29	26	235	76.2	1.50
2	32	35	32	240	76.2	1.60
3	40	41	38	260	101.6	2.50
4	50	53	50	280	101.6	2.50
5	65	70	66	320	114.3	3.50
6	80	85	81	375	114.3	3.80
7	100	104	100	400	154	7.40
8	125	129	125	665	219.1	17.00
9	150	154	150	719	219.1	18.00

3240/MM

FILTR TYPU "Y" CLAMP
SPAW / SPAW (PE. / PE.)

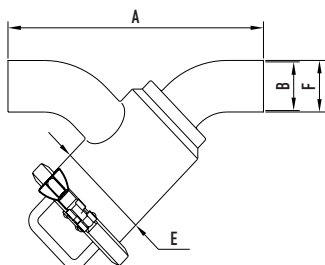

Nº	DN (cal)	F (mm)	B (mm)	A (mm)	E (mm)	(kg)
1	1	25.4	22.1	213	76.2	1.70
2	1 1/2	38.1	34.8	242	101.6	2.90
3	2	50.8	47.5	300	101.6	3.20
4	2 1/2	63.5	60.2	348	114.3	3.80
5	3	76.2	72.9	378	114.3	4.10
6	4	101.6	97.4	468	154	7.30
7	6	152.4	146.8	652.7	219.1	-